

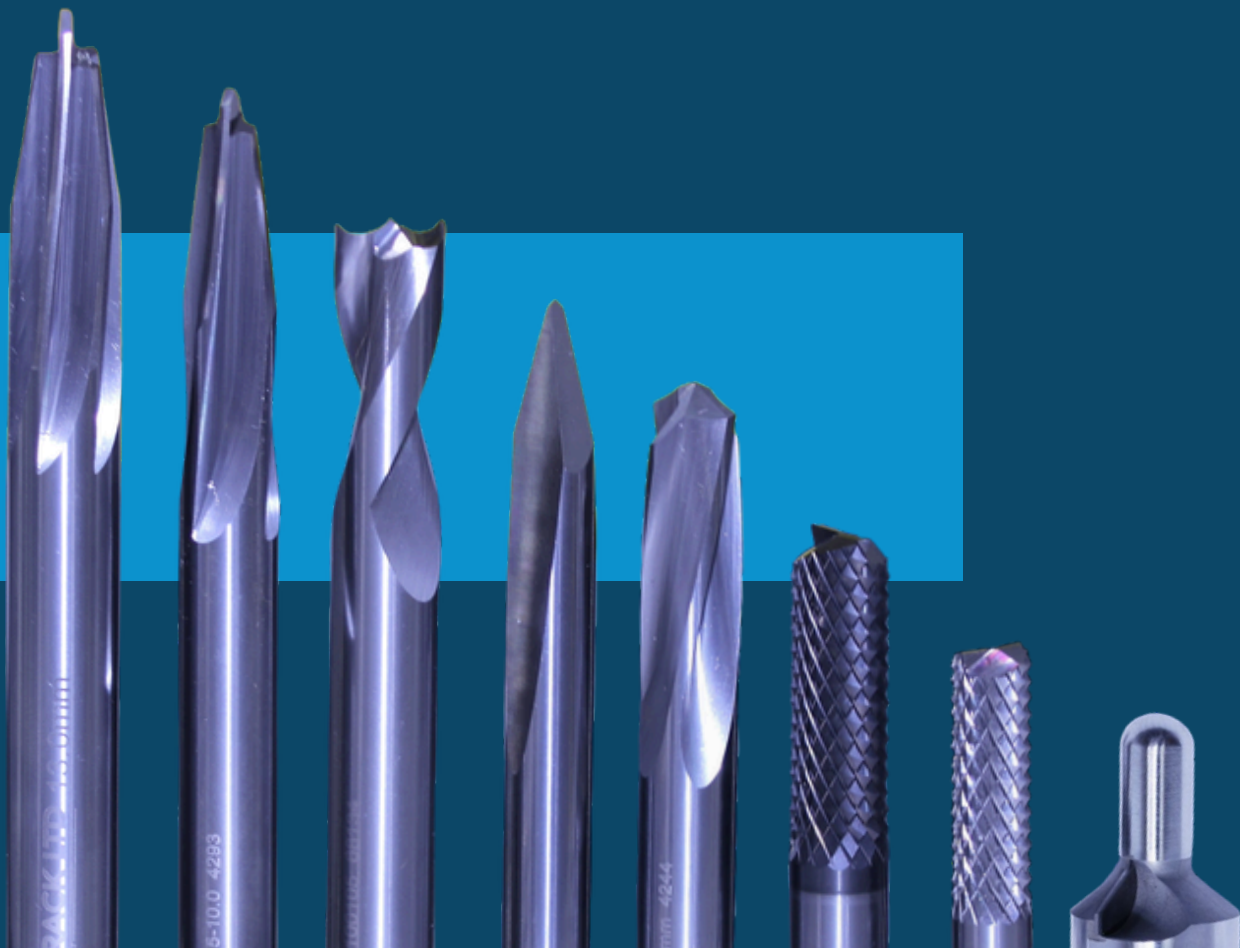

GANDTRACK LTD

Cutting Tool Specialists



COMPOSITE CUTTING TOOLS AND ACCESSORIES





GANDTRACK LTD IS A MARKET LEADER IN THE DESIGN AND MANUFACTURE OF SPECIALIST CUTTING TOOLS FOR AEROSPACE AND ASSOCIATED INDUSTRIES

We manufacture high quality tooling including drills, reamers, routers and countersinks for composite cutting applications. We supply to a variety of specialist markets with a focus on innovation and quality.

About Us	4
Company History	5
Tool Management, Facilities and Inspection	6
Life Cycle Support and Key Personnel	7
Products	8
Solid Carbide Drilling	9
Reamers	17
Routers	20
Countersinks	25
Microstop Drill Cages	31
Rivet Millers and Shavers	36
Seti-Tec	38
HSS and Cobalt Drilling	40
Counterbores	42
Hole saws	44
Adapter Drills	46
Diamond Hand Files	48
Go/No-Go Gauges	49

**FROM OUR MANUFACTURING SITE AND
HEAD OFFICE IN OLDHAM, LANCASHIRE
WE DESIGN AND MANUFACTURE CUTTING
TOOLS FOR GLOBAL DISTRIBUTION**

We manufacture cutting tools for the following industries:



COMMERCIAL AEROSPACE



MOTOR SPORT

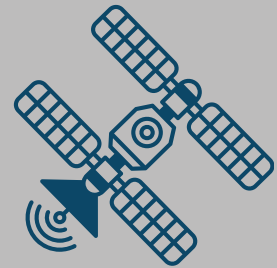

SPACE



MARITIME



DEFENCE

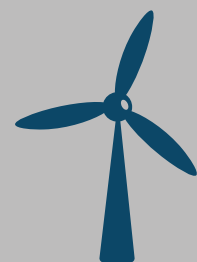

RENEWABLE ENERGY



PROTOTYPES



MOVIE PROPS



RE-WORK + RE-GRIND



GANDTRACK IS A MARKET LEADER IN THE DESIGN AND MANUFACTURE OF SPECIALIST CUTTING TOOLS FOR AEROSPACE AND ASSOCIATED INDUSTRIES

We manufacture cutting tools for the following industries:



COMMERCIAL AEROSPACE



MOTOR SPORT

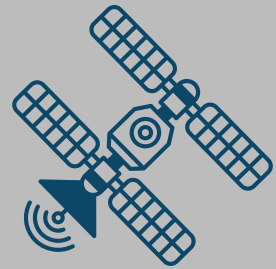

SPACE



MARITIME



DEFENCE

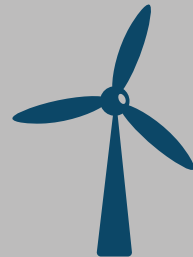

RENEWABLE ENERGY



PROTOTYPES



MOVIE PROPS



RE-WORK + RE-GRIND

COMPANY HISTORY

Established in 1981, Gandtrack Ltd emerged as a pioneering force in composite cutting tool solutions. Originally incorporated to contribute to the development of the British Aerospace EAP (Experimental Aircraft Program), which later evolved into the Eurofighter Typhoon, Gandtrack quickly became synonymous with innovation.

Throughout the 1980s and 1990s, Gandtrack played a crucial role in supplying cutting tools for BAE sites but the company's journey soon saw strategic relocations in Saddleworth before the current office in Oldham, showcasing a commitment to growth. Gandtrack continued its ascent, introducing initiatives like the vending machine system at Safran in 2008, revolutionizing tool management.

International expansion followed with the establishment of sister company, Gandtrack Asia Sdn Bhd in 2008, supporting customers in Malaysia and Asia.

Over the years, Gandtrack invested in cutting-edge quality control technology, acquiring Walter Helicheck machines, culminating in the purchase of the latest Walter Helitronic Power in 2019.

Today, Gandtrack stands as a symbol of continuous innovation and commitment to excellence in the cutting tool industry.

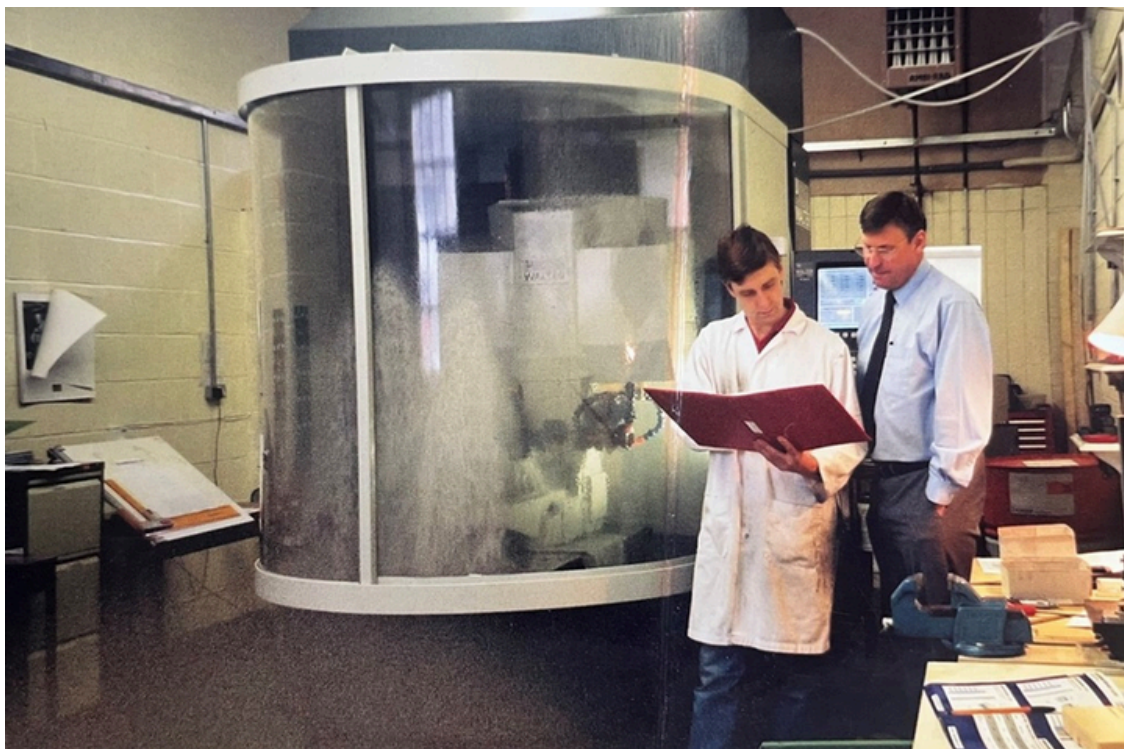



TOOL MANAGEMENT SYSTEMS

We are passionate about providing solutions that exceed expectations. Vending systems have been developed in direct response to the requirement of on-site precision tools.

Supply point systems tool vending machines allow our clients to manage stock levels efficiently. We receive information from these vending machines to monitor the usage of our products, which ensures you don't get left without products when you need them. It eliminates the threat of theft, human error and stock management issues. Every tool has a part number so we know the exact quantities that have been taken from the system.

FACILITIES

Gandtrack has always endeavoured to never sacrifice quality in its products, investing heavily in new technologies and machine software in production and inspection. Our aim is to supply superior products with the right geometry for the materials being used. This ensures longer lasting cutting tools, which produce the best quality finish and the highest quality products.

INSPECTION

At Gandtrack, we employ the Walter Helicheck 3D and Advanced for achieving the highest levels of accuracy in metrology technology. As the demands for tool precision and productivity increase within industries such as metal processing, aerospace engineering and automotive manufacturing, the significance of employing such meticulous measuring technology could not be more important.

We are able to document our level of accuracy in line with industry standards such as AS9100 and ISO9001. With this technology you can have the confidence that we can manufacture conformed, high quality bespoke tools to the quantities you require.

LIFECYCLE SUPPORT

Gandtrack is your one-stop shop for quality cutting tools that will last. Based in Oldham, Lancashire, we offer a complete product lifecycle support service, including our innovative smart tooling process. Beyond providing expert technical support, we specialize in cost-effective regrinding and refurbishment, ensuring your tools enjoy a prolonged lifespan (size permitting). Instead of buying new, explore the option of our re-grind service:

- ✓ CNC P.C.D Lapping - Regrind
- ✓ CNC and Conventional Tool Grinding
- ✓ Manufacture and refurbishment of bespoke form tools and standard cuttings tools
- ✓ High performance drills and cutting tools reground to original specification
- ✓ Tool reclamation and coating available
- ✓ Modification to customer's own standard and indexable tooling to drawings
- ✓ Quick turnarounds from bespoke items to batch work

KEY PERSONNEL

- BRIAN HIRST (Managing Director)
- ADRIAN JONES (Director)
- NATHAN MAYBERRY (Workshop Manager)

Our team have vast experience in delivering effective solutions in cutting tool applications and tool management. We are proud to be a market leader and will suggest alternative methods in tool design where we can see benefits.





OUR PRODUCTS

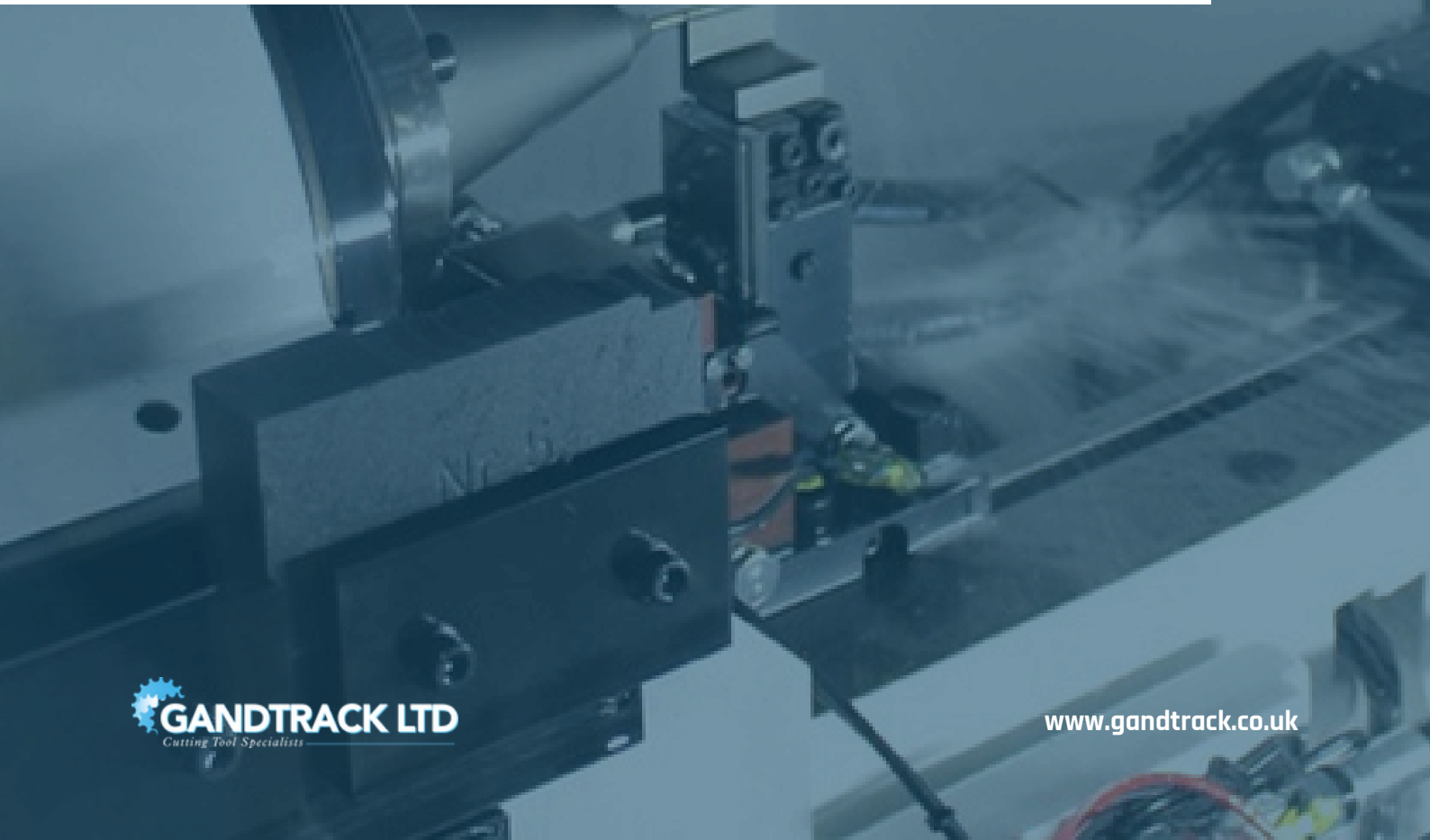

SOLID CARBIDE DRILLING





GT-15 SOLID CARBIDE DRILL REAMER

Gandtrack GT-15 Drill Reamer has been designed to drill composite materials. It is designed to drill from solid, or to open pre-drilled holes in composite materials such as:

- Carbon Fibre
- Reinforced Polymers
- Glass Fibre
- Graphite Composites
- Carbon and thin Aluminium stack

The GT-15 Drill Reamer gives the operator the luxury of drill and ream in one operation by hand, eliminating separate drilling, opening and reaming operations.

Drilling operations performed by hand with a drill bush or CNC machine, Gandtrack's unique cutting geometry provides the best cutting action for both operator and machine producing a high quality tolerance hole.

3D Image



The GT-15 Drill Reamer is available in any size from 2.38mm up to 10mm.

Within the Aerospace sector, quality of finished holes is paramount. Less re-work required to save time and money, the GT-15 Drill Reamer gives the operator confidence in their ability to perform, giving excellent working life and price per hole as per industry demands.



From 10mm-16mm we have introduced a **six flute** option with a reduced shank for the use of manual or CNC drilling operations.

The GT-15 six flute can be used to drill from solid or piloted hole. Drill bushes are recommended.



DLC COATING AVAILABLE





GT-50 SOLID CARBIDE DAGGER DRILLS

Gandtrack's GT 50 solid carbide Dagger Drill with a unique drilling geometry has continuously proven to be the best design for drilling carbon fibre components because of its ability to reduce delamination whilst producing a quality sized hole.

The GT 50 is well suited for hand operations or CNC programs. The Dagger drill with its special point makes it easy for drilling of Carbon composite materials, giving confidence for both operator and programmer.

This can drill materials such as:

- Carbon Fibre
- Glass Fibre
- Graphite Composites

Advantages of using dagger drills include:

Exceptional Hardness: This ensures extended tool life.

Precision:

Solid Carbide dagger drills will provide outstanding and accuracy during drilling.

Geometry:

Reduced drilling forces and heat generation reduces the risk of material damage.

Chip Evacuation:

Enhanced chip evacuation for improved hole quality due to reduced risk of material damage.

Surface Finish:

Suitable for applications demanding high levels of accuracy and a superior surface finish.

Bespoke sizes are available upon request.

3D Image





GT-105 DOUBLE MARGIN BURNISHING DRILL

The GT-105 Double Margin Burnishing Drill has been designed for drilling materials such as:

- Carbon
- Carbon and Aluminium stack
- Carbon and thin Titanium stack

The four lands on the drill produces a burnishing effect and stability.

The second land also has contact with the hole wall, giving the drill added stability, this creates an accurate and quality hole.

14/28 UNF threaded shanks available - Size on request.

Also available with a step.



3D Image



GT-38 RADIUS POINT DRILL

The radius point drill gives an excellent cutting action when opening pilot holes in Carbon composites by hand.

The GT-38 is available in any size from 2.5mm to 10mm.

3D Image





GT-250 SOLID CARBIDE KEVLAR DRILL

Gandtrack GT-250 Solid Carbide Kevlar Drill cutting geometry has been vigorously used on all types of Kevlar material, including armour technology manufacture, and has proven in all cases to be the best cutting action for both the material and the operator.

Also tried and tested on Kevlar products for unmanned drones and ultra-light solar powered aircraft.

Fluff free finish and minimal volcano effect leads to hours saved in producing quality holes in Kevlar materials.

Two flute style for diameters up to 12mm and a new 3 flute version is available for larger diameters.

Available with a pilot

3D Image





GT-12-AL-TIN COATED DRILLS

Special cutting geometry for aerospace-grade alloys.

- Hand and machine drilling of aerospace grade aluminium
- Carbon fibre
- Reinforced polymers
- Glass fibre
- Carbon and Aluminium stack



In conjunction with hardened drill bush



GT-12-LEFT HAND HELIX DRILL

Pilot hole required to locate non-cutting pilot, right hand cutting with left hand helix drives swarf forward and evacuates through the pilot hole, minimising swarf damage on inner surface of the carbon.

- Right hand cut, left hand helix.
- Designed for non-bonded metal-carbon stacks.

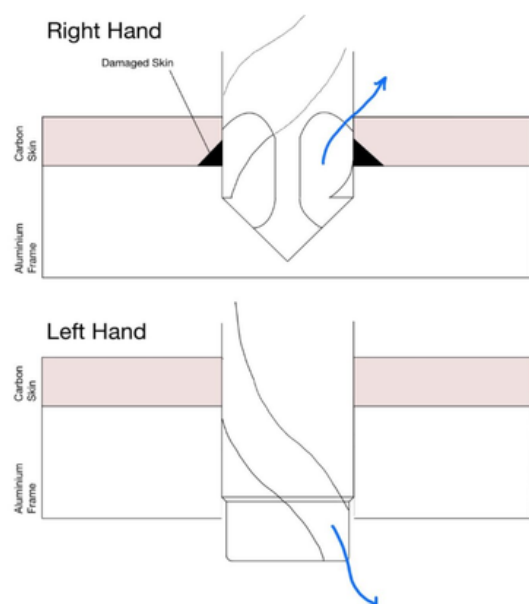

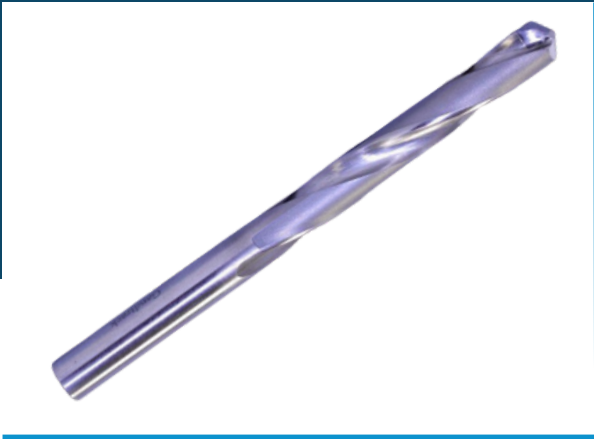

CARBIDE TIPPED DRILL

Allows the benefit of the carbide tip cutting performance but with a HSS body. With small diameters or long lengths, the HSS body is less rigid than Carbide and runs less risk of breaking.

This drill can be used through a bush.

- Sizes available upon request



GT-240 INVERTED POINT DRILL

The GT-240 is designed for drilling holes to size in one operation in composite materials. The trepanning cutting action reduces risk of delamination.

Generally used on automatic feed machine guns.

The GT-240 Inverted point drill is available in any size from 2.5mm to 10mm

3D Image





TRI-FLUTE DRILL

Three flute drills provide better hole size control and surface finish than two flute due to the additional cutting edges. The three lands provide superior guiding support, have a thicker web and may be used with heavy feed rate.

- Lead angle 120°, 140°, 150° or bespoke angles are available upon request.
- Designed to drill materials such as Carbon and Aluminium stack.



STEP TRI-FLUTE DRILL

The step drill is a conventional Tri-flute which has had a second diameter created by grinding down a portion of the larger diameter.

These tools are used to enlarge previously drilled holes.

- Non cutting pilot

Cutting pilots are available upon request.
Intermediate sizes available on request.

Reamers

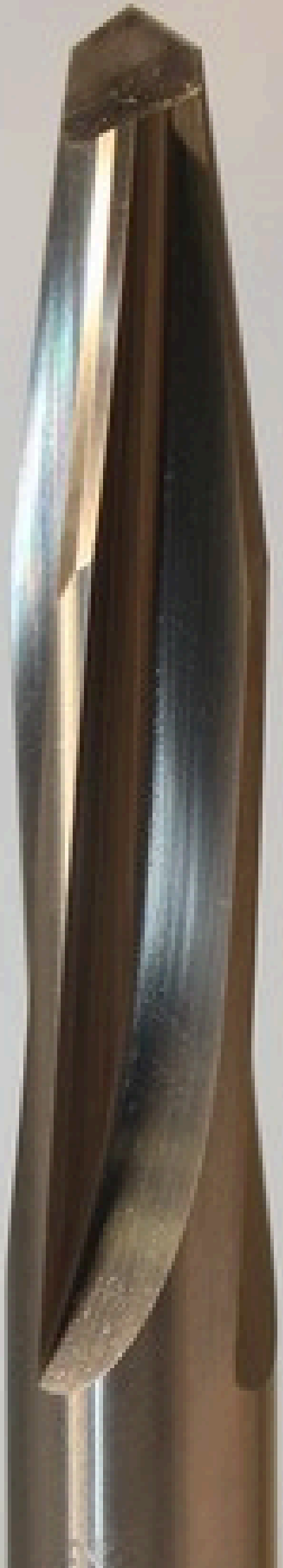



SOLID CARBIDE TAPER LEAD REAMER

The taper lead reamer can be used by hand or by CNC.

Designed to open pre-drilled holes in composite materials such as:

- Carbon Fibre
- Reinforced Polymers
- Glass Fibre
- Graphite Composites
- Carbon and thin Aluminium stack

Gandtrack's unique cutting geometry provides the best cutting action for both operator and machine producing a high quality tolerance hole and excellent working life and price per hole as per industry demand.

- Sizes: 2.38-16mm cutter diameter
- Also available with 1/4 x 28 unf threaded shank.
- Sizes available upon request



HSS HAND REAMER

Available in Solid Carbide or HSS.

Gandtrack HSS/Solid Carbide Drill Reamer is designed to open pre-drilled holes in composite materials.

Gandtrack's unique cutting geometry provides the best cutting action for both operator and machine producing a high quality tolerance hole and excellent working life and price per hole as per industry demand.

- Sizes: 2.38-16mm cutter diameter
- Also available with 1/4 x 28 unf threaded shank.
- Sizes available upon request



SOLID CARBIDE MACHINE REAMER

Designed to open pre-drilled holes in composite materials such as:

- Carbon Fibre
- Reinforced Polymers
- Glass Fibre
- Graphite Composites
- Carbon and thin Aluminium stack

Gandtrack's unique cutting geometry provides the best cutting action for both operator and machine producing a high quality tolerance hole and excellent working life and price per hole as per industry demand.

- Sizes: 2.38-16mm cutter diameter
- Also available with 1/4 x 28 unf threaded shank. size on request.
- Sizes available upon request



HSS PILOTED REAMER

The piloted reamer is made of high-speed steel and is used by hand to create the final sizing of holes.

- Sizes available upon request

Routers





PCD ROUTERS

When machining carbon composites, PCD Routers improve cut and trim quality, allows accurate forming of corner and edge shapes and provides up to 10 times longer tool life.

- Sizes: 6-20mm Cutter diameter – intermediate sizes available upon request.
- 1-5 flutes

Style:

- Straight
 - Ball nose
 - Taper
 - Over centre
-
- Re-tip and re-lap available.
 - Corner radius and additional sizes are available upon request.



SOLID CARBIDE KEVLAR ROUTER

The Kevlar router is designed for machining aramid materials such as kevlar.

Scissor cutting action provides fluff free cutting.

- Available from 6mm to 10mm Diameter



GT-14-ROUTER

The GT-14 is a solid carbide Diamond cut router and can be used on the following materials:

- Carbon Fibre
- Reinforced Polymers
- Glass Fibre
- Graphite Composites
- Carbon and Aluminium stack

Sizes available-

- 10mm diameter, 75mm overall length, 25mm flute length
- 8mm diameter, 63mm overall length, 25mm flute length
- 6mm diameter, 63mm overall length, 19mm flute length

DIAMOND LIKE COATED GT-14

The GT-14 is a solid carbide Diamond cut router and can be used on the following materials:

- Carbon Fibre
- Reinforced Polymers
- Glass Fibre
- Graphite Composites
- Carbon and Aluminium stack



GT-140 SOLID CARBIDE ROUTER

The GT-140 has been developed for machine routing in glass reinforced composite materials, such as Fibreglass and G10, along with many forms of plastic and non-metallic materials used in a wide range of industries.

Sizes available-

- 10mm diameter, 75mm overall length, 25mm flute length
- 8mm diameter, 63mm overall length, 25mm flute length
- 6mm diameter, 63mm overall length, 19mm flute length



GT-141 SOLID CARBIDE ROUTER

The GT-141 is designed for trimming and finishing in demanding applications requiring minimal fibre break out and delamination.

Manufactured with fewer flutes than the GT-140 to avoid clogging during demanding applications.

Available in 12mm and 10mm diameters with end cut, drill point and no end cut.



GT-90 SHEAR CUT ROUTER

- Extended flute design for swarf evacuation
- Cutting flute 24mm
- Extended flute 45mm
- OAL 100mm
- Diameter 10mm

Additional sizes available upon request.



GT-14 DLC COATED ROUTER

- Diamond Cut Router/Burr
- DLC Coated for extended tool life
- Generally used for routing or trimming either machine or hand held

Sizes available upon request.



GT-14 DLC COATED ROUTER

The GT-14 is a solid carbide Diamond cut router and can be used on the following materials:

- Carbon Fibre
- Reinforced Polymers
- Glass Fibre
- Graphite Composites
- Carbon and Aluminium stack

Sizes available upon request.

Countersinks





GT-60 PCD COUNTERSINK - REMOVABLE PILOT

When machining carbon composites, PCD Countersinks improve hole quality, allows accurate forming of holes and provides up to 10 times longer tool life.

- Sizes: 10/14/17/21mm cutter diameter.
- 1-6 Flutes.
- Inclusive angle: 90/100° or bespoke angles are available upon request.
- Removeable Pilot diameter: 2-16mm.
- Removeable Pilot length: 5-30mm.
- Threaded shank: M6x1/M8x1.
- Additional sizes available upon request.

Available with a solid carbide cutting pilot.



PCD COUNTERSINK - INTEGRAL PILOT

- Sizes: 10/14/17/21mm cutter diameter.
- 1-6 Flutes.
- Inclusive angle: 90/100°
- Pilot diameter: 2-20mm.
- Threaded shank: M6x1/M8x1.
- Additional cutting sizes, pilot sizes and bespoke angles are available upon request.

Extended pilot of bespoke sizes available upon request.



GT-13 SOLID CARBIDE STEM COUNTERSINK

The GT-13 can be used for hand or machine operations. This can drill materials such as:

- Composites
- Glass fibre
- Metallic
- Sizes up to 9.525mm body



DIAMOND COUNTERSINK

The diamond grit countersink is used for roughing out on carbon, grinding precise, chip free into existing holes to be finished with PCD.

- HSS body.
- 44-60 Grit.
- Sizes, grit and angles are available upon request.



PILOTED COUNTERSINKS

The diamond grit countersink is used for roughing out on carbon for a PCD Countersink to finish to a quality surface.

- 44-60 Grit



PILOTED COUNTERSINKS

Available in solid carbide or HSS/Co and used on materials such as:

- Composites
- Glass Fibre
- Metallic

Can be used on machine or by hand.



**HSS COBALT COUNTERSINK -
INTEGRAL PILOT**



**HSS COBALT COUNTERSINK -
REMOVEABLE PILOT**

- 8% Cobalt
- 2 or 3 flutes
- Threaded shank: M6x1 or M8x1
- Inclusive Angle: 90°/100°/120° and Sizes: 10/14/17/21mm Cutter Diameter
- Replacement pilots available on request
- Microstop drill cages available upon request
- Bespoke angles and sizes available upon request

PILOTED MICROSTOP COUNTERSINKS

3 FLUTES-INTEGRAL PILOT-THREADED SHANK

90°/100°/120°

(CAGES AVAILABLE ON REQUEST)

M42-HSS-E 8% COBALT



CODE	PILOT DIAMETER	CUTTER DIAMETER	INCLUSIVE ANGLE	THREAD	RADIUS BETWEEN PILOT & FLUTE
S2.38-90-10	3/32	10.00	90	M6X1	0.010"-0.015
S3.17-90-10	1/8	10.00	90	M6X1	0.015"-0.020"
S3.96-90-10	5/32	10.00	90	M6X1	0.020"-0.025"
S4.76-90-10	3/16	10.00	90	M6X1	0.020"-0.025"
S4.76-90-14	3/16	14.00	90	M6X1	0.025"-0.030"
S6.35-90-14	1/4	14.01	90	M6X1	0.025"-0.030"
S7.94-90-17	5/16	17.00	90	M6X1	0.035"-0.040"
S9.52-90-21	3/8	21.00	90	M6X1	0.035"-0.040"
S2.38-100-10	3/32	10.00	100	M6X1	0.010"-0.015
S3.17-100-10	1/8	10.00	100	M6X1	0.015"-0.020"
S3.96-100-10	5/32	10.00	100	M6X1	0.020"-0.025"
S4.76-100-10	3/16	10.00	100	M6X1	0.020"-0.025"
S4.76-100-14	3/16	14.00	100	M6X1	0.025"-0.030"
S6.35-100-14	1/4	14.01	100	M6X1	0.025"-0.030"
S7.94-100-17	5/16	17.00	100	M6X1	0.035"-0.040"
S9.52-100-21	3/8	21.00	100	M6X1	0.035"-0.040"
S2.38-120-10	3/32	10.00	120	M6X1	0.010"-0.015
S3.17-120-10	1/8	10.00	120	M6X1	0.015"-0.020"
S3.96-120-12	5/32	10.00	120	M6X1	0.020"-0.025"
S4.76-120-10	3/16	10.00	120	M6X1	0.020"-0.025"
S4.76-120-14	3/16	14.00	120	M6X1	0.025"-0.030"
S6.35-120-14	1/4	14.01	120	M6X1	0.025"-0.030"
S7.94-120-17	5/16	17.00	120	M6X1	0.035"-0.040"
S9.52-120-21	3/8	21.00	120	M6X1	0.035"-0.040"

CODE	PILOT DIAMETER	CUTTER DIAMETER	INCLUSIVE ANGLE	THREAD	DECIMAL EQUIVALENT
SUNF3/32-100-1/2	3/32	1/2	100	1/4-28	.0938
SUNF1/8-100-1/2	1/8	1/2	100	1/4-28	.1250
SUNF5/32-100-1/2	5/32	1/2	100	1/4-28	.1563
SUNF3/16-100-1/2	3/16	1/2	100	1/4-28	.1875
SUNF7/32-100-1/2	3/16	1/2	100	1/4-28	.2188
SUNF1/4-100-1/2	1/4	1/2	100	1/4-28	.2500

PILOT DIAMETER TOLERANCE = -0.0015"

ADDITIONAL SIZES ON REQUEST

PILOTED MICROSTOP COUNTERSINKS

M42-HSS-E 8% COBALT

2 OR 3 FLUTES-REMOVABLE PILOT-THREADED SHANK



90°/100°/120° (CAGES AVAILABLE ON REQUEST)

CODE	PILOT DIAMETER	PILOT SHANK DIAMETER	INCLUSIVE ANGLE	CUTTER DIAMETER	NUMBER OF FLUTES	THREAD
D2.38-90-10	3/32	2.00	90	10.00	2	M6X1
D3.17-90-10	1/8	2.50	90	10.00	2	M6X1
D3.96-90-10	5/32	3.50	90	10.00	2	M6X1
D4.76-90-10	3/16	3.50	90	10.00	2	M6X1
D4.76-90-14	3/16	4.00	90	14.00	2	M6X1
D6.35-90-14	1/4	4.00	90	14.01	2	M6X1
D7.94-90-17	5/16	5.00	90	17.00	3	M6X1
D9.52-90-21	3/8	5.00	90	21.00	3	M6X1
D2.38-100-10	3/32	2.00	100	10.00	2	M6X1
D3.17-100-10	1/8	2.50	100	10.00	2	M6X1
D3.96-100-10	5/32	3.50	100	10.00	2	M6X1
D4.76-100-10	3/16	3.50	100	10.00	2	M6X1
D4.76-100-14	3/16	4.00	100	14.00	2	M6X1
D6.35-100-14	1/4	4.00	100	14.01	2	M6X1
D7.94-100-17	5/16	5.00	100	17.00	3	M6X1
D9.52-100-21	3/8	5.00	100	21.00	3	M6X1
D2.38-120-10	3/32	2.00	120	10.00	2	M6X1
D3.17-120-10	1/8	2.50	120	10.00	2	M6X1
D3.96-120-12	5/32	3.50	120	10.00	2	M6X1
D4.76-120-10	3/16	3.50	120	10.00	2	M6X1
D4.76-120-14	3/16	4.00	120	14.00	2	M6X1
D6.35-120-14	1/4	4.00	120	14.01	2	M6X1
D7.94-120-17	5/16	5.00	120	17.00	3	M6X1
D9.52-120-21	3/8	5.00	120	21.00	3	M6X1

CODE	PILOT DIAMETER	SHANK DIAMETER	MATERIAL
PILOT2.38-2.00	3/32	2.00	TOOL STEEL
PILOT3.17-250	1/8	2.50	TOOL STEEL
PILOT3.96-3.50	5/32	3.50	TOOL STEEL
PILOT4.76-3.50	3/16	3.50	TOOL STEEL
PILOT4.76-4.00	3/16	4.00	TOOL STEEL
PILOT6.35-4.00	1/4	4.00	TOOL STEEL
PILOT7.94-5.00	5/16	5.00	TOOL STEEL
PILOT9.52-5.00	3/8	5.00	TOOL STEEL

Microstop Cages





66004S MICROSTOP DRILL CAGE

- Spindle mounted on 4 ball bearings
- Bearings protected by dust shields
- Stainless steel bearing body
- Stainless steel lock nut left hand
- 1/4" (6.35mm) shank
- 5/16" (8mm) shaft travel
- 7/8" (22.225mm) cutter capacity
- 0.0005" (0.0106mm) increment depth adjustment
- Rated at 10,000 RPM
- 6mm viewing slots

66003S MICROSTOP DRILL CAGE

- Spindle mounted on 3 ball bearing
- 10,000 maximum RPM
- Bearings protected by dust shields front and back
- Stainless steel bearing body
- Left hand stainless steel lock nut with flats or wrench
- Microstop depth adjustment 0.00042" (0.0101668mm) per increment
- Removable foot peices; No-Mar or stainless steel
- .275" (7mm) Shank.
- 5/16" (8 mm) Shaft Travel.
- 3/4" (19.05mm) Cutter Capacity.
- Removable vacuum attachments

Technical information (mm)

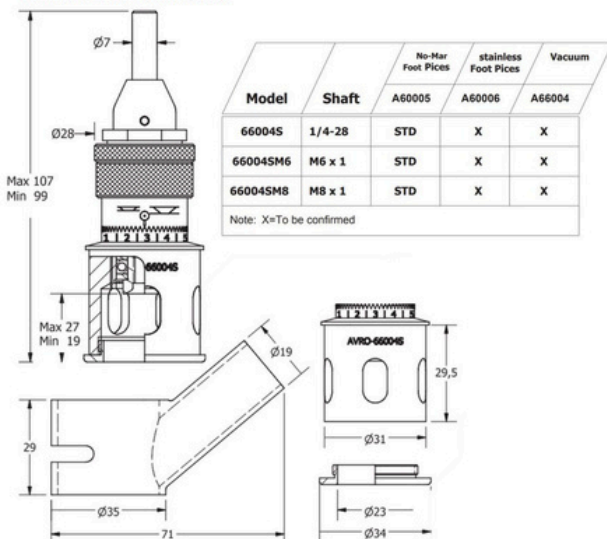

Model	Shaft	Foot Pieces		
		No-Mar	stainless	Vacuum
		A60010	A60009	A66003
66003S	1/4-28	STD	X	X
66003SM6	M6 x 1	STD	X	X
66003SM8	M8 x 1	STD	X	X

Note: X=To be confirmed



Technical information (mm)

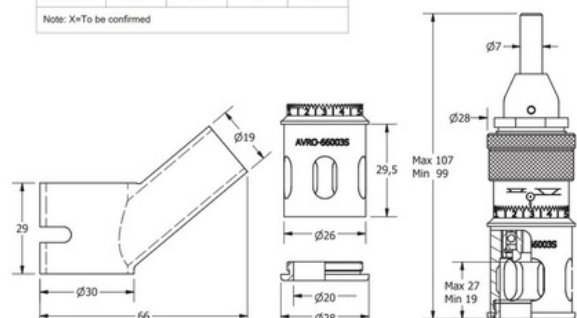



66002S MICROSTOP DRILL CAGE

- Spindle mounted on 4 ball bearing 10,000 maximum RPM
- Bearings protected by dust shields front and back
- Stainless steel bearing body
- Left hand stainless steel locking nut with flats or wrench
- Microstop depth adjustment 0.00042" (0.0101668mm) per increment
- Removable skirts no-mar or stainless steel
- Removable vacuum attachments
- .275" (7mm) Shank.
- 5/16" (8 mm) Shaft Travel.
- 9/16" (14,28 mm) Cutter Capacity.

Model	Shaft	Foot Pieces		
		No-Mar Foot Pieces	stainless Foot Pieces	Vacuum
66002S	1/4-28	STD	X	X
66002SM6	M6 x 1	STD	X	X

Note: X=To be confirmed



Technical information (mm)

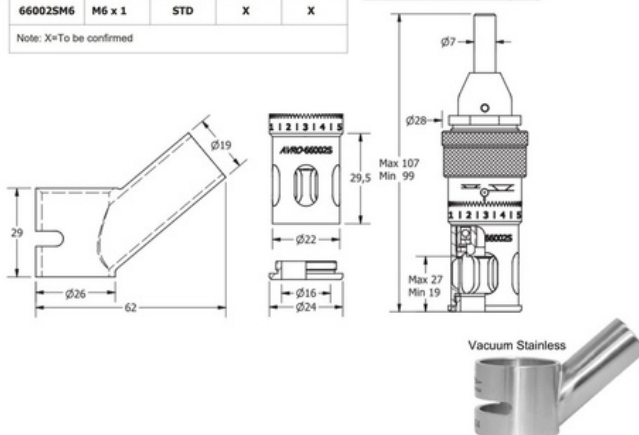

67000 MICROSTOP DRILL CAGE

- Spindle mounted on 6 ball bearings
- Stainless steel bearing body
- Stainless steel lock nut left hand
- 1/4" (6.35mm) shank
- 1/4" (6.35mm) shaft travel
- 7/16" (11.11mm) cutter capacity
- 0005(0.0127mm) increment depth adjustment
- Rated at 5,000 RPM

Model	Shaft	Foot Pieces		
		No-Mar Foot Pieces	stainless Foot Pieces	Vacuum
67000	1/4-28	STD	X	X
67000M6	M6 x 1	STD	X	X

NOTE: X=To be confirmed

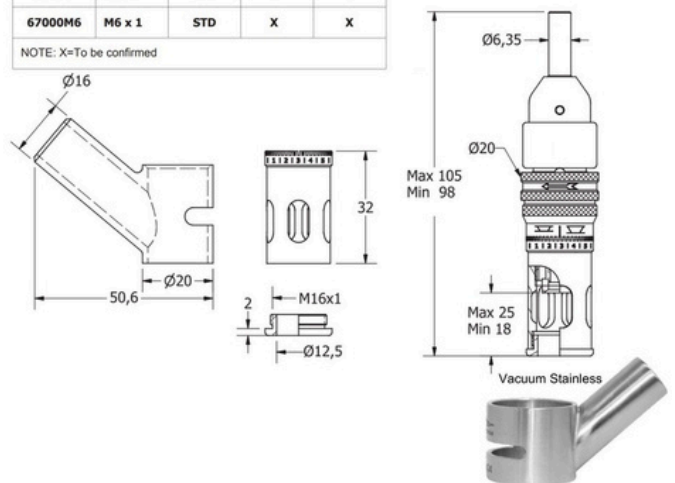



60500 HEAVY DUTY MICROSTOP DRILL CAGE

- Spindle mounted on 5 ball bearings
- Bearings protected by dust shields
- Stainless steel bearing body
- Stainless steel lock Nut left hand
- 3/8" (9.52mm) Shank with 3 Flats.
- 9/16" (14mm) Shaft Travel.
- 1-1/2" (38.1mm) Cutter Capacity
- 0.001" (0.025mm) Increment Depth Adjustment
- Rated at 10,000 RPM.

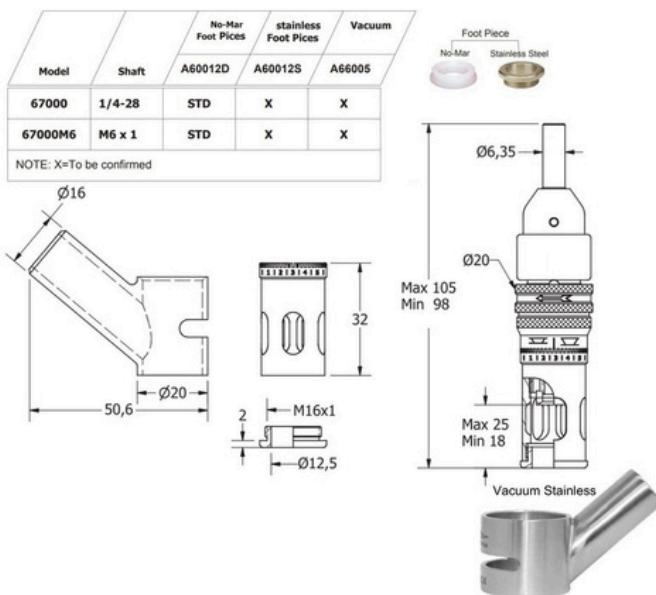

69000 BALL BEARING MICROSTOP

- Spindle mounted on 2 ball bearings
- Bearings protected by dust shields.
- Stainless steel bearing body.
- Stainless steel lock Nut left hand .
- 3/16" (4.76mm) Shank.
- 1/8" (3.17 mm) Shaft Travel.
- 9/16" (14 mm) Cutter Capacity.
- 0.0005" (0.0106mm) Increment Depth Adjustment
- Rated at 3,000 RPM .

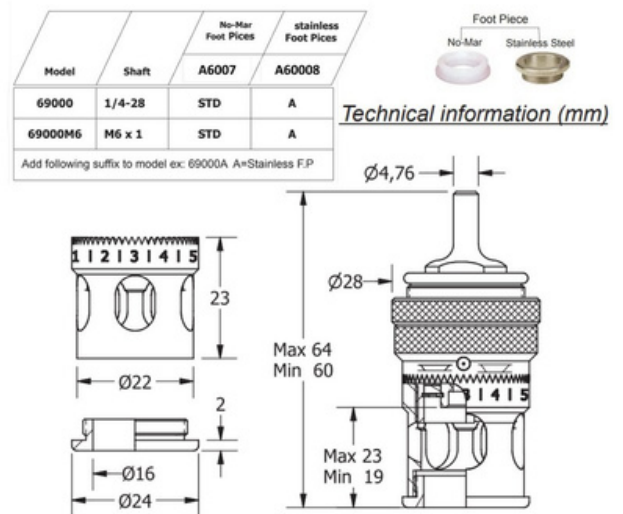

CAGE NUMBER	VACCUUM NUMBER	EXTRACTION DIA
66004S	A66004	19MM
66003S	A66003	19MM
6602S	A66002	19MM
67000	A66005	16MM



Rivet Millers & Shavers





PRECISION GROUND RIVET MILLER

The precision ground rivet miller is for chatter free (low RPM).
 Carbide slug.

Unique 8 flute centre cutting design resulting in elimination of chatter, superior control for operator and smooth finish.

- 1/4x28 male thread
- M6 male thread
- 10mm DIA x 28mm OAL
- Regrind available on quantity



RIVET SHAVER

Precision ground for chatter free cuts, smoother for cutter and operation.
 Carbide slug.

- 7/16" 1/4"x26 Thread
- 5/16" 1/4"x26 Thread
- Intermediate sizes available upon request.

WALTER HELITRON

SETI-TEC





SETI-TEC DRILL

A bespoke Solid Carbide drill designed by Gandtrack to suit the Seti-Tec drill gun.

8mm thread.

Solid carbide.

All sizes available upon request.



SETI-TEC COUNTERSINK DRILL

A bespoke countersink designed by Gandtrack to suit the Seti-Tec drill gun.

This tool is designed to drill and countersink to save operations and time.

With the 2 flute geometry for cutting Carbon fibre & Carbon Stacks.

Solid carbide.

All sizes available upon request.



HSS and Cobalt Drilling



**SPECIALIST IN HOLE PREPARATION AND
FINISHING FOR THE AEROSPACE INDUSTRY**



HSS DRILL



8% COBALT BACK SPOT-FACE CUTTERS

- Bayonet
- Threaded
- Pin type pilots



HSS STEP 5 FLUTE DRILL



HSS/COBALT DRILL



HSS/COBALT STEP DRILL



HSS SUB-LAND DRILL

WALTER HELITRON

Counterbores

GANDTRACK
7.6 X 10.31
9056



HSS/CO COUNTERBORE

- 8% Cobalt
- Integral or removeable pilot
- Corner radius
- M6, M8, 1/4X28 Thread

Additional sizes available upon request.



PCD COUNTERBORE

- When machining carbon composites, PCD Counterbores improve hole quality, allows accurate forming of holes and provides up to 10 times longer tool life.
- Sizes: 10/14/17/21mm cutter diameter.
- 1-6 Flutes.
- Removeable or integral pilot.
- Pilot diameter: 2-16mm.
- Pilot length: 5-30mm.
- Threaded shank: M6x1/M8x1.
- Additional sizes available upon request.

WALTER HELITRON

Hole Saws





DIAMOND GRIT HOLE SAW

Solid Carbide Hole saw with Diamond Coated Cutting edge. The diamond edge maximises performance and helps retain a sharp cutting.



HSS COBALT HOLE SAW

8% Cobalt

Diameter sizes upon request.

Numbers of teeth upon request.

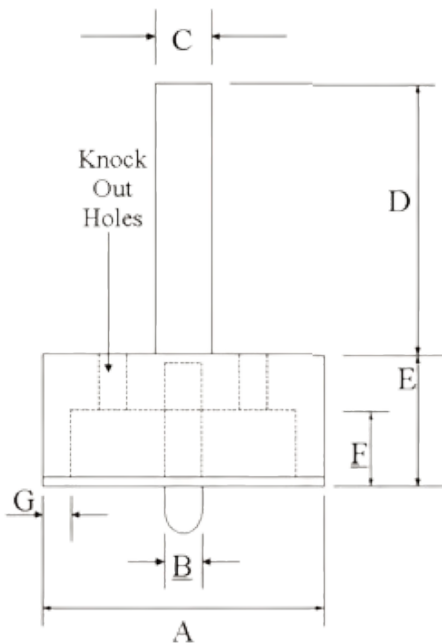

Get In Touch



0161 627 2627



sales@gandtrack.co.uk



www.gandtrack.co.uk



Unit 8, Gladstone Business Park,
Gladstone Street,
Moorhey, Oldham, OL4 1BE

